



X-ONE Evo

STREAMLINED,
EFFECTIVE
& PURE



Nestled quietly within the heart of Monaco is our small, but perfectly formed factory, hand-crafting espresso machines since 1956. We combine a genuine passion for innovation and coffee excellence, with exceptional quality and reliability to produce the finest machines for any circumstance or environment.

www.conti-espresso.com

ESTD 1956

Conti
MONACO



X-ONE Evo



The benchmark mid volume machine, simple, sleek design using modern materials, intuitive controls and effective technology, the X-ONE Evo consistently surpasses expectations.

At the core of the CONTI machinery portfolio, the X-ONE Evo has found itself a broad and diverse fan base, with class leading features, this model really is a jack of all trades!

Available in a choice of colour finish, 2 or 3 group model and espresso or tall cup configuration, the X-ONE Evo has something for everyone, whilst taking extraction to the next level. We have taken the proven technology from within the CC100 range and 'supercharged' it, increasing capacity under pressure and offering further control to the operator.



Flow Control

The X-ONE Evo features the incredible temperature stability achieved by PID control together with our unique 'Flow Control' system, this allows additional, small adjustments to be made to the group temperature, ensuring that coffee is extracted efficiently and consistently time and again.



Diagnostics

Unique software diagnostics provide the user with important maintenance advice such as cleaning, service and water filter change reminders – all displayed on digital screen.



Steam Levers

Dual Function Lever activated steam wands, making texturing milk simple and fast, saving the barista valuable time. These levers also feature a sprung loaded 'purge' function to help eliminate milk build up within the steam wand itself.

Additional Features:

Shot Timers

Measure the extraction parameters shot after shot, ensuring performance is controlled and monitored in service.

Auto On/Off

Programme your machine to automatically switch to Eco mode during quieter periods, overnight or even when you are closed for a day, then back on before service begins, saving staff and electricity costs and prolonging life of machine components.

Adjustable Hot Water Temperature

Fine tune your entire drinks portfolio to use the machine water reservoir to make that perfect Long Black or Americano.

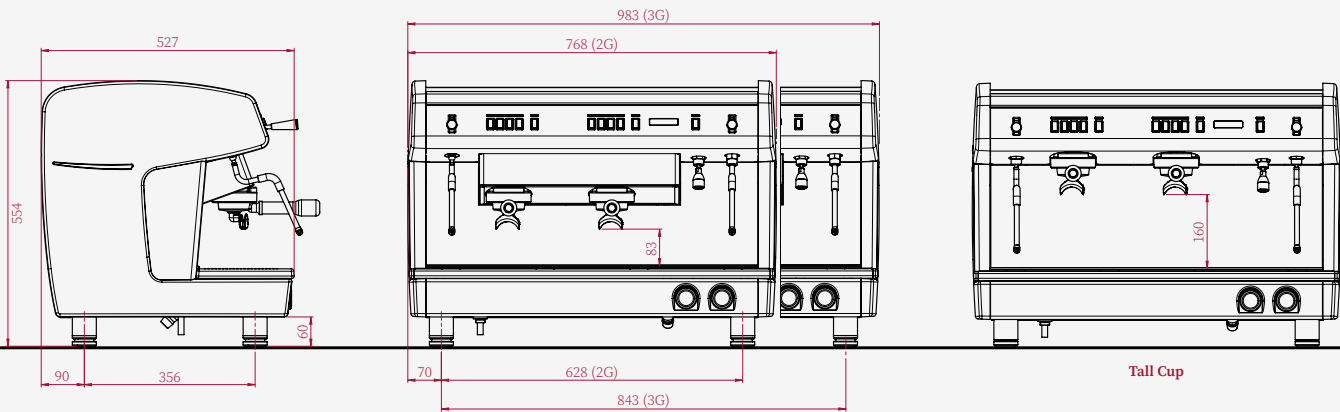

Precision Pre-Infusion

Change coffees and doses without fear, by adjusting both, volume of pre-brew and also bloom period, better extractions are simplicity themselves.



	2 Group	3 Group
Height (mm)	554	554
Width (mm)	768	983
Depth (mm)	527	527
Weight (kg)	58	74
Steam Boiler Size (Litres)	13	20
Coffee Boiler Size (Litres)	n/a	n/a
Group Element (W)	n/a	n/a
Steam Boiler Element (W)	3500 (option 4200)	6000 (option 4700)
Coffee Boiler Element (W)	n/a	n/a
Total Power (W)	3800 (option 4500)	6300 (option 5000)
Voltage (V)	230 (option 400)	400 (option 230)



Colour Options:

-  Jet Black
-  Traffic White
-  Carmine Red



Conti Monaco
Email: conti@conti-espresso.com
Tel: +377 93 10 43 43
www.conti-espresso.com

1 Avenue Albert II
B.P.119
MC 98007
Monaco Cedex

 @conti_monaco
 conti monaco